

Moonsoaker

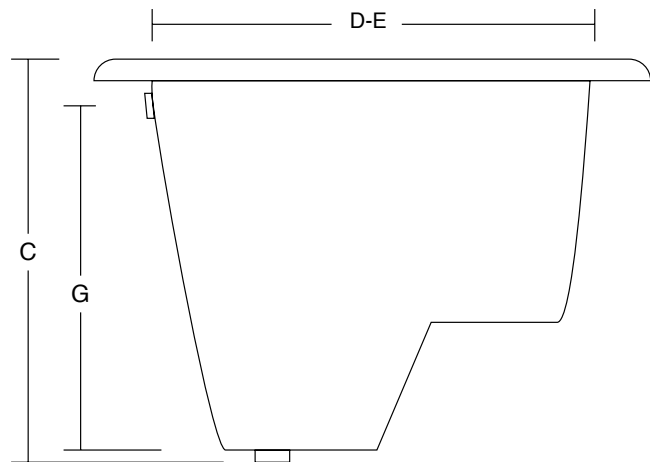

MODEL	A	B	C	D	E	F	G
Moonsoaker	41 ³ / ₄	41 ³ / ₄	34	38	38	11 ¹ / ₄	29 ⁷ / ₈

Water Capacity 68 Gallons

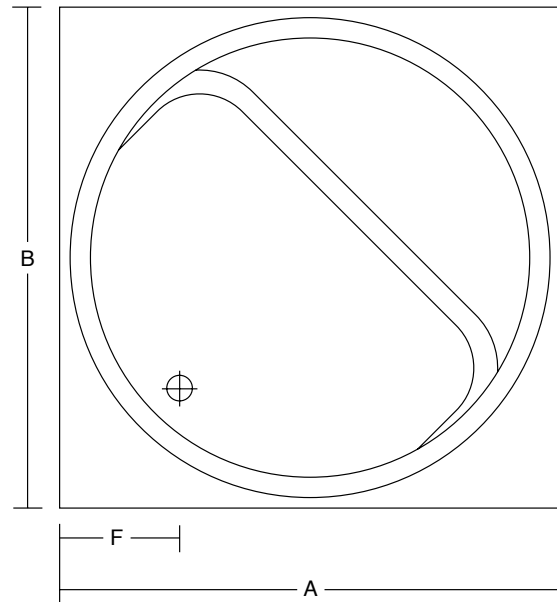

Specifications

The bath unit shall be a gel-coated, heavy-duty fiberglass reinforced unit to provide a sanitary, unbroken, smooth surface.

Reinforcing and contouring gives added strength. Warranted against factory defects for three years.

All product measurements are to the outside of flange. Measurements plus (+) or minus (-) 1/4".

All Venco Products are Canadian Standards Association certified



7584 Vantage Place, Delta, BC V4G 1A5
 Phone (604) 940-4960 • Fax (604) 940-9733
 email: venco@telus.net
www.venco.ca